

Industrial Brakes

Stromag SHD9

Hydraulic Disc Brakes



Photo courtesy of FM GRU



Emergency stopping brake for Hoisting applications.

SHD9 caliper belongs to the SIME Brakes SHD range of Stromag. This fail-safe single-spring hydraulic caliper is an appreciated answer to the technological challenge imposed by lifting equipment. Robust construction and simplicity of operation bring to this caliper a high reliability. Its compact and light weight design allows an easy mounting and operation in a restricted space.

A large torques range enables the installation of this caliper on multiple equipments.

Hydraulic Power Pack and further options can be provided in accordance with the installation requirement.

Applications

- Tower Cranes
- Port Cranes
- Offshore applications

Benefits include

- Hydraulic caliper
- Direct acting caliper / few components
- Designed for 200,000 cycles
- Compact and light weight design
- Braking force from 43 kN to 100 kN
- Protection level C3-H
- Positive lining fastening : easy replacement
- Opening and wear monitoring switches preset in factory
- Option : Closing monitoring switch

TECHNICAL DATA / DIMENSIONS

Revision number: T10042-01-E Revision date: 31.08.2017

Caliper SHD9

- Fail safe braking
- Braking by spring application
- Hydraulic release
- Opening proximity switch for PLC (induction sensor)
- Lining wear detectors
- Association with discs thickness 30 mm

Working conditions:

- Ambient temperature: -10°C to +60°C
 - Relative humidity $\leq 70\%$
 - Dust in atmosphere $\geq 65\mu\text{m}$
- Other conditions, consult Stromag.

Use:

- Emergency stopping brake in case of overspeed or loss of electrical supply

Options:

- Lining wear proximity switch
- Discs thickness $24 \leq e < 30 \text{ mm}$.
- Option GF :
Ambient temperature:
- Dynamic braking : -30°C to +60°C
- Parking braking : -40°C to +60°C
- Marine protection

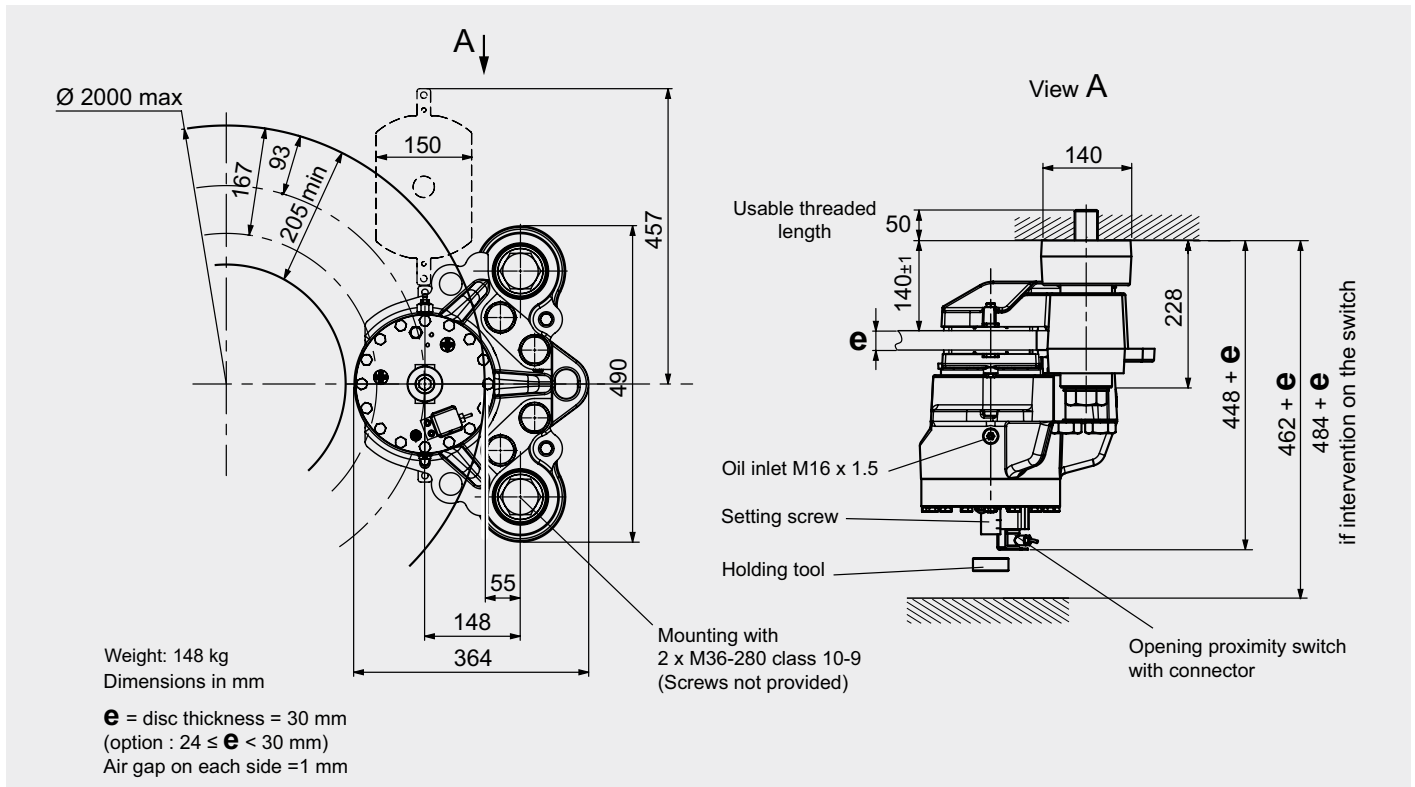

Torque and effort values are subject to a variation of $\pm 10\%$
Response time at nominal torque ≤ 0.3

Designation	Caliper		SHD9-6
	Lining		US2-1
Braking force BF for air gap disc/lining of 2x1mm	Dynamic	N	100 000
	Static	N	88 000
Linear speed of the disc	m/s		≤ 10
Dynamic braking torque BT (m.N) for 1 caliper and disc ØD (mm) / D max $\leq 2000\text{mm}$	N.m		$BT = BF (D/2000 - 0,093)$
Regulation pressure	Minimum	bar	180
	Maximum	bar	200
Setting pressure limit valve of hydraulic unit	bar		220
Total volume of oil displaced for air gap disc/lining of:			
2 x 1 mm (nominal opening)	cm ³		28
2 x 1,5 mm (nominal opening and wear before setting)	cm ³		39

Electrical data :

Opening proximity switch

Standard caliper and caliper option GF
3 wires PNP NO
10 to 58 VDC 200 mA with connector M12

Wear proximity switch (option):

Temperature -10°C to +60°C
3 wires PNP NO
10 to 58 VDC 200 mA with connector M12
Temperature -40°C to +60°C / Option GF
3 wires PNP NO
10 to 36 VDC 200 mA with connector M12