



**PERIFLEX® NA**  
SHAFT COUPLINGS





# DECADES OF EXPERIENCE

Across Industries and Applications



**Founded in 1932, Stromag™ has grown to become a globally recognized leader in the development and manufacture of innovative power transmission components for industrial drivetrain applications.**

Stromag engineers utilize the latest design technologies and materials to provide creative, energy-efficient solutions that meet their customer's most challenging requirements.

Stromag's extensive product range includes flexible couplings, disc brakes, limit switches, an array of hydraulically, pneumatically, and electrically actuated brakes, and a complete line of electric, hydraulic and pneumatic clutches.

Stromag engineered solutions improve drivetrain performance in a variety of key markets including energy, off-highway, metals, marine, transportation, printing, textiles, and material handling on applications such as wind turbines, conveyor systems, rolling mills, agriculture and construction machinery, municipal vehicles, forklifts, cranes, presses, deck winches, diesel engines, gensets and stage machinery.

VISIT US ON THE WEB AT **STROMAG.COM**



# CONTENT

### PERIFLEX® VN SHAFT COUPLINGS: VII

<b>COUPLING AT A GLANCE</b>	<b>4</b>
Product range	
Benefits include	
Applications areas	
Fail-safe device	
Torque range	
Instruction for the designer	
Application factor	
Use in potentially explosive environments	
Storing flexible rubber elements	
<b>Assignment of Periflex® Shaft Couplings to Electric Motors</b>	<b>10</b>
<b>Periflex® Shaft Couplings output table</b>	<b>12</b>
<b>SERIES</b>	<b>14</b>
Periflex® NC	<b>14</b>
Periflex® NA	<b>15</b>
Periflex® NS	<b>16</b>
Periflex® NL	<b>18</b>
Periflex® NP	<b>19</b>
Periflex® ND	<b>20</b>
Periflex® NB	<b>22</b>
<b>Characteristic</b>	<b>23</b>
<b>Coupling Design, question sheet</b>	<b>26</b>
<b>Use in potentially explosive environments, question sheet</b>	<b>27</b>

# FLEXIBLE COUPLINGS

## AT A GLANCE

### PERIFLEX® NA SHAFT COUPLING PRODUCT RANGE

#### PERIFLEX® NC

Nominal torque range: 35 – 20,500 Nm



Standard Shaft Coupling with fail-safe device

#### PERIFLEX® NA

Nominal torque range: 35 – 20,500 Nm



Shaft Coupling without fail-safe device

#### PERIFLEX® NP

Nominal torque range: 70 – 2,200 Nm

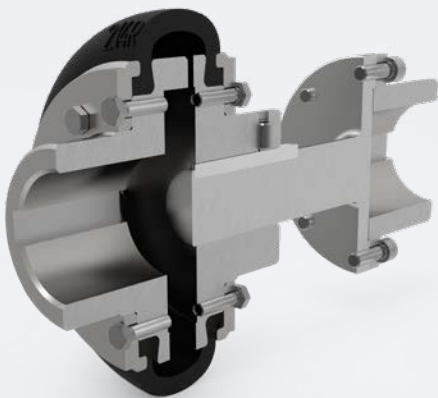

Shaft Coupling with dismantling part

#### PERIFLEX® ND

Nominal torque range: 545 – 13,700 Nm

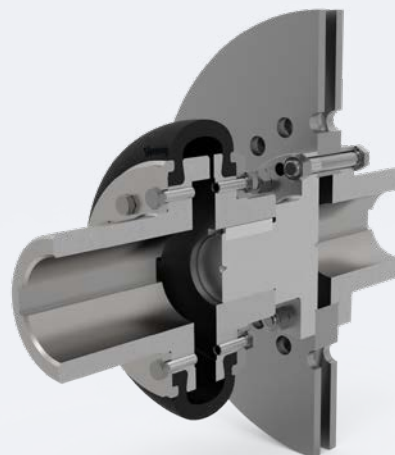

Shaft Coupling with brake disc

### PERIFLEX® NS

Nominal torque range: 70 – 13,700 Nm



Shaft Coupling with taper lock bushing

### PERIFLEX® NL

Nominal torque range: 70 – 2,200 Nm

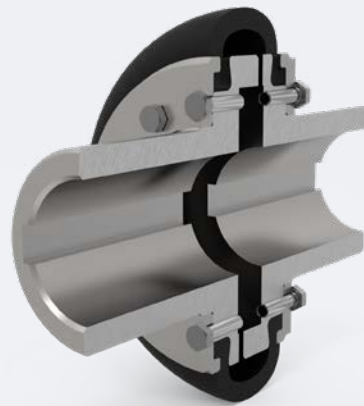

Shaft Coupling with longer hub

### PERIFLEX® NB

Nominal torque range: 545 – 13,700 Nm

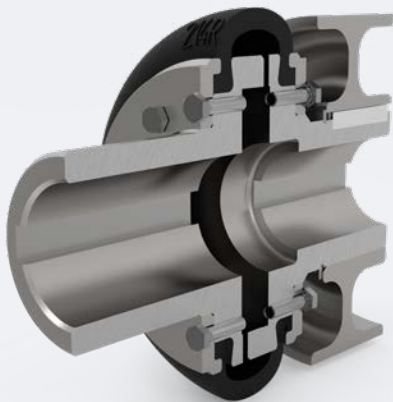

Shaft Coupling with brake drum

# FLEXIBLE COUPLINGS

---

## AT A GLANCE

## STROMAG PERIFLEX® SHAFT COUPLINGS

### BENEFITS INCLUDE

---

- The Stromag Periflex® Shaft Coupling is a highly flexible rubber-fabric coupling, particularly suitable for connecting two shafts in diesel engine and electric drives
- Due to the special design of the shaft tire, the Periflex® Shaft Coupling can absorb extremely large displacements in every direction with low restoring forces, without noticeable wear and tear
- As standard, the tire can be radially mounted and dismantled using a separation joint without moving the connected machines
- The Periflex® Shaft Coupling transmits the torque free of backlash
- It is suitable for absorbing torque shocks and dampens vibrations
- Covers the torque range from 35 to 20,500 Nm

### APPLICATIONS AREAS

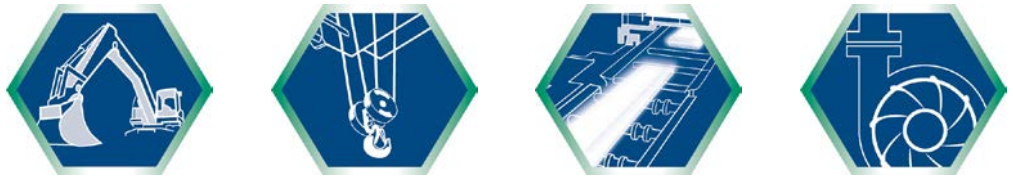

- The Periflex® Shaft Couplings is especially suited for use in metallurgical plants, in crane construction as well as for roller table drives
- Other areas of application include electrical power units, compressors, the construction machinery industry, crane construction and general mechanical engineering

### FAIL-SAFE DEVICE

The Stromag Periflex® Shaft Couplings are standard equipped with a fail-safe device. A rupture in the hub element causes claws to intermesh, forming a torsionally rigid, backlash connection between the drive and output sides. Temporary emergency operation is possible with limited torque. The permissible torques and speeds must be calculated separately by means of torsional vibrations transmitted via torsionally rigid structure.

On customer request the Periflex® NA (PNA) is still available without fail-safe device.

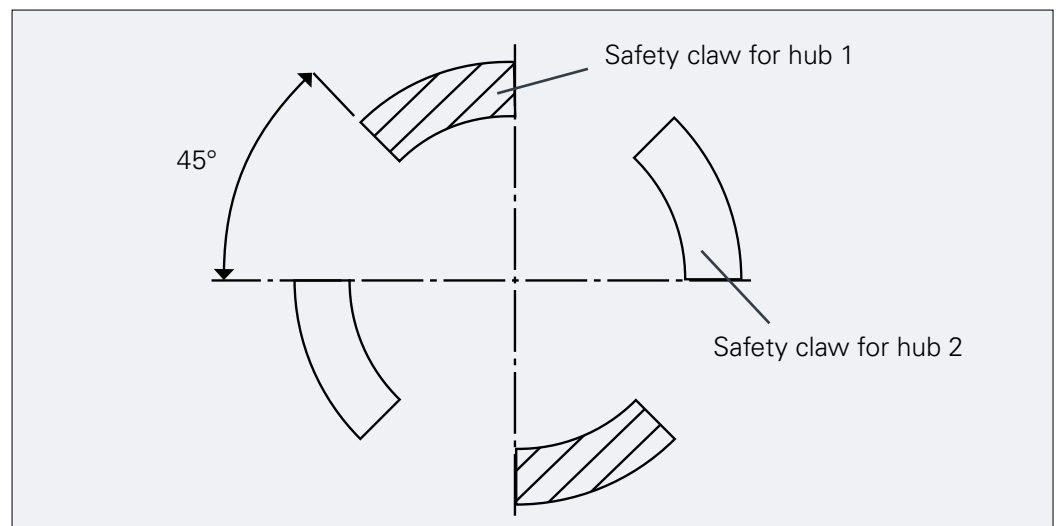

# FLEXIBLE COUPLINGS

---

## AT A GLANCE

### TORQUE RANGE

---

- Periflex® NC: 35 up to 20,500 Nm
- Periflex® NA: 35 up to 20,500 Nm
- Periflex® NS: 70 up to 13,700 Nm
- Periflex® NL: 70 up to 2,200 Nm
- Periflex® NP: 70 up to 2,200 Nm
- Periflex® ND: 545 up to 13,700 Nm
- Periflex® NB: 545 up to 13,700 Nm

### INSTRUCTION FOR THE DESIGNER

---

The coupling hubs and pressure rings are made of steel and have a corrosion protection layer.

The shaft tire is made of natural rubber with fabric inserts. In the R-tires, the fabrics are laid in radial alignment and in X-tires they are diagonal. Different technical properties are achieved by changing the type of fabric arrangement. Due to diagonally arranged fabric layers they are better suited for reverse operation or shock loads.

The Stromag Periflex® Shaft Coupling develops a certain axial force under the influence of torque and speed, which must be absorbed by suitable bearings. To determine the axial forces that occur, the Stromag technical document "Determining the resulting axial forces  $F_A$ " must be requested.

Periflex® Shaft Couplings can be used in the temperature range from -50°C to +80°C. The flexible element can reach higher temperatures than the ambient temperature because of damping work. When covering the coupling with a protective cover, this must be considered by ensuring adequate ventilation and heat dissipation.

Flexible couplings usually represent the safety breaking point of a drive train. Overloading the drive train therefore usually leads to failure of the flexible coupling elements. This behavior is deliberate and protects the entire system from unforeseen damage. Any consequential damage resulting from this safety function of the coupling must be considered in advance by the plant designer and monitored or prevented with appropriate measures.

The key factors to consider when choosing a Periflex® Shaft Coupling are the loads from transferred power and torsional vibrations. The value  $T_{KN}$  is to be used for stationary operating modes, while  $T_{Kmax}$  is to be used for non-stationary operating modes. When selecting based on the system torque, the application factors  $f_{ANW}$  must be taken into account. Stromag departments can provide support with the design, specifically in calculating the torsional vibrations. We therefore ask you to complete and return the question sheet annexed to this catalogue.



### APPLICATION FACTOR

If safety factors have not been considered when designing the plant, the following application factors ( $f_{ANW}$ ) should be considered in the design phase:

Application factor  $f_{ANW}$

I	II	III
1.25	1.5	2.0

To determine the application factor, the driven machines are divided into the following groups:

- I. Work machines with uniform power consumption, such as small machine tools with rotating main movement, small woodworking machines, small fans, small centrifugal pumps, generators, belt conveyors.
- II. Medium-duty work machines with non-uniform power consumption, such as diesel and gas engines, chain conveyors, crane trolleys, generators, elevators, looms, etc.
- III. Heavy-duty machines or with non-uniform power consumption, such as excavator drives, thrashing machines, heavy drilling rigs, paper calenders, centrifuges.

### USE IN POTENTIALLY EXPLOSIVE ENVIROMENTS



The coupling conforms to the requirements under Directive 2014/34/EU and can be used as follows:

- a. **Zone 1** (gas, Category 2G) in Groups IIA, IIB, and IIC, T4
- b. **Zone 2** (gas, Category 3G) in Groups IIA, IIB, and IIC, T4
- c. **Zone 21** (dust, Category 2D)
- d. **Zone 22** (dust, Category 3D) for dusts with a minimum ignition energy  $> 3$  mJ, T 125°C

The ignition protection class of the coupling is "c". This means that the protective measures comply with DIN EN ISO 80079-37 (Protection by constructional safety "c")

Stromag Periflex® Shaft Coupling compliance with the requirements for each of these zones / categories is documented in the form of the following codes on our products:

Use in gas atmospheres:

CE II 2G Ex h IIC (T4) Gb

Use in dust atmospheres:

CE II 2D Ex h IIIC T120°C Db

Use in potentially explosive environments must be based on the request form annexed to this catalogue.

### STORING FLEXIBLE RUBBER ELEMENTS

Flexible rubber elements retain their properties for several years if stored correctly. It is essential to protect the stored parts from oxygen, ozone, light, heat, moisture and solvents. Solvents, fuels, lubricants, chemicals, acids, disinfectants and similar substances must not be stored in the storage room. The storage temperature should not drop below +10°C and should not exceed +25°C. All UV light sources are harmful and should be avoided. Ozone-generating devices such as light sources and electric motors must be kept away from the storage location. The relative humidity should not exceed 65%. Further details can be found in the standards DIN 7716 and ISO 2230.

# FLEXIBLE COUPLINGS

## Stromag Periflex® Shaft Couplings

### Assignment of Periflex® Shaft Couplings to electric motors

Assignment of Periflex® Shaft Couplings to three-phase asynchronous motors of gear sizes 56 to 315 with cage rotor according to EN 50347.

Motor size	Motor power at 3000 rpm (2-pole)		Coupling size PNA	Motor power at 1500 rpm (4-pole)		Coupling size PNA	Cylinder shaft end D x L [mm]	
	P [kW]	T [Nm]		P [kW]	T [Nm]		3000 rpm	≤ 1500 rpm
56 M	0.09	0.3	1	0.06	0.4	1	9 x 20	
	0.12	0.4	1	0.09	0.6	1		
63 M	0.18	0.6	1	0.12	0.8	1	11 x 23	
	0.25	0.8	1	0.18	1.2	1		
71 M	0.37	1.2	1	0.25	1.6	1	14 x 30	
	0.55	1.8	1	0.37	2.4	1		
80 M	0.75	2.4	1	0.55	3.5	1	19 x 40	
	1.1	3.5	1	0.75	4.8	1		
90 S	1.5	4.8	1	1.1	7.0	1	24 x 50	
90 L	2.2	7.0	1	1.5	9.6	1	24 x 50	
100 L	3	9.6	2	2.2	14	2	28 x 60	
				3	19	2		
112 M	4	13	2	4	25	2	28 x 60	
132 S	5.5	18	2	5.5	35	2	38 x 80	
	7.5	24	2					
132 M	-	-	-	7.5	48	2	38 x 80	
160 M	11	35	6	11	70	6	42 x 110	
	15	48	6					
160 L	18.5	59	6	15	96	16	42 x 110	
180 M	22	70	16	18.5	118	16	48 x 110	
180 L	-	-	-	22	140	16	48 x 110	
200 L	30	96	16	30	191	40	55 x 110	
	37	118	16					
225 S	-	-	-	37	236	40	55 x 110	60 x 140
225 M	45	143	16	45	287	40	55 x 110	60 x 140
250 M	55	175	40	55	350	40	60 x 140	65 x 140
280 S	75	239	40	75	478	63	60 x 140	75 x 140
280 M	75	287	40	90	573	63	60 x 140	75 x 140
315 S	110	350	40	110	700	63	60 x 140	80 x 170
315 M	132	420	63	132	840	125	60 x 140	80 x 170

The assignment takes application factor II into account in normal load cases.

For systems with predominantly periodic excitations, the design must be in accordance with DIN 740 Part 2. Stromag departments can provide support with the design, specifically in calculating the torsional vibrations.

# FLEXIBLE COUPLINGS

## Stromag Periflex® Shaft Couplings

Assignment of Periflex® Shaft Couplings to three-phase asynchronous motors of gear sizes 56 to 315 with cage rotor according to EN 50347.

Motor size	Motor power at 1000 rpm (6-pole)		Coupling size PNA	Motor power at 750 rpm (8-pole)		Coupling size PNA	Cylinder shaft end D x L [mm]	
	P [kW]	T [Nm]		P [kW]	T [Nm]		3000 rpm	≤ 1500 rpm
56 M	-	-	-	-	-	-	9 x 20	
63 M	-	-	-	-	-	-	11 x 23	
71 M	-	-	-	-	-	-	14 x 30	
80 M	0.37 0.55	3.5 5.3	1 1	-	-	-	19 x 40	
90 S	0.75	7.2	1	-	-	-	24 x 50	
90 L	1.1	11	1	-	-	-	24 x 50	
100 L	1.5	14	2	0.75 1.1	10 14	2 2	28 x 60	
112 M	2.2	21	2	1.5	19	2	28 x 60	
132 S	3	29	2	2.2	28	2	38 x 80	
132 M	4 5.5	38 53	2 6	3	38	2	38 x 80	
160 M	7.5	72	6	4 5.5	51 70	6 6	42 x 110	
160 L	11	105	16	7.5	96	16	42 x 110	
180 M	-	-	-	-	-	-	48 x 110	
180 L	15	143	16	11	140	16	48 x 110	
200 L	18.5 22	177 210	16 40	15	191	40	55 x 110	
225 S	-	-	-	18.5	236	40	55 x 110	60 x 140
225 M	30	287	40	22	280	40	55 x 110	60 x 140
250 M	37	353	40	30	382	63	65 x 140	65 x 140
280 S	45	430	63	37	471	63	65 x 140	75 x 140
280 M	55	525	63	45	573	63	65 x 140	75 x 140
315 S	75	716	63	55	700	63	65 x 140	80 x 170
315 M	90	860	125	75	955	125	65 x 140	80 x 170

The assignment takes application factor II into account in normal load cases.

For systems with predominantly periodic excitations, the design must be in accordance with DIN 740 Part 2. Stromag departments can provide support with the design, specifically in calculating the torsional vibrations.

# FLEXIBLE COUPLINGS

## Stromag Periflex® Shaft Couplings

Output table, couplings with R-Tires

Coupling Size	Tire	Nominal Torque	Maximum Torque	Adm. Alternating Torque	Adm. Speed	Adm. axial Displacement	Axial Stiffness
		$T_{KN}$ Nm	$T_{Kmax}$ Nm	$T_{KW}$ Nm	$n_{max}$ rpm	$\Delta K_a$ mm 4)	$C_a$ N/mm 2) 3)
1 R	201 R	35	75	15	5000	1,0	60
2 R	203 R	70	150	30	5000	1,0	110
6 R	206 R	135	300	55	5000	1,5	130
16 R	210 R	270	600	110	4000	2,0	120
40 R	214 R	545	1200	215	4000	2,5	150
63 R	218 R	1000	2400	400	3000	3,0	160
125 R	222 R	2200	4800	880	3000	3,5	180
200 R	225 R	3400	7500	1360	2500	4,5	400
300 R	426 R	5500	12000	2200	2300	5,0	340
400 R	828 R	8200	18000	3280	1800	5,5	250
800 R	1230 R	13700	30000	5480	1500	6,0	1000
1500 R	1832 R	20500	45000	8200	1000	6,0	1800

Output table, couplings with X-Tires

Coupling Size	Tire	Nominal Torque	Maximum Torque	Adm. Alternating Torque	Adm. Speed	Adm. axial Displacement	Axial Stiffness
		$T_{KN}$ Nm	$T_{Kmax}$ Nm	$T_{KW}$ Nm	$n_{max}$ rpm	$\Delta K_a$ mm 4)	$C_a$ N/mm 2) 3)
1 X	201 X	35	75	15	5000	1,0	90
2 X	203 X	70	150	30	5000	1,0	140
6 X	206 X	135	300	55	5000	1,5	150
16 X	210 X	270	600	110	4000	2,0	150
40 X	414 X	545	1200	215	4000	2,5	80
63 X	418 X	1000	2400	400	3000	3,0	80
125 X	422 X	2200	4800	880	3000	3,5	100
200 X	225 X	3400	7500	1360	2500	4,5	400
300 X	426 X	5500	12000	2200	2300	5,0	400
400 X	828 X	8200	18000	3280	1800	5,5	300
800 X	1230 X	13700	30000	5480	1500	6,0	1000
1500 X	1832 X	20500	45000	8200	1000	6,0	1800

1) At max. speed

2) This value must be reduced by the temperature factor when the coupling temperatures are higher than 30 °C (see page 25).

3) Material- related tolerances up to ± 15% are possible.

4) To be able to use the full axial or angular displacement, a design without claws must be used

# FLEXIBLE COUPLINGS

## Stromag Periflex® Shaft Couplings

	Adm. radial Displacement	Radial Stiffness	Adm. angular Displacement	Torsional stiffness					Relative Damping
				$C_{T \text{ dyn}}$ Nm/rad 2) 3)					
	$\Delta K_r$ mm 1) 2)	$C_r$ N/mm 2) 3)	$\Delta K_w$ 1) 2) 4)	$0,0 \times T_{KN}$	$0,25 \times T_{KN}$	$0,5 \times T_{KN}$	$0,75 \times T_{KN}$	$1,0 \times T_{KN}$	$\psi$
	0,70	60	2,0	295	280	285	305	335	1,2
	0,75	120	2,0	690	645	675	770	910	1,2
	1,0	120	2,0	1100	1000	1100	1300	1650	1,2
	1,3	110	2,0	2100	2050	2250	2650	3150	1,2
	1,6	150	2,0	5000	4650	4950	5400	5950	1,2
	2,1	150	2,0	6800	6200	7200	9900	15000	1,2
	2,5	200	2,0	14000	13200	18200	28700	44500	1,2
	3,0	400	2,0	22500	23000	33000	46000	61000	1,2
	3,5	500	2,0	29000	28000	50000	84000	128000	1,2
	3,7	400	2,0	29000	29000	52000	87000	132000	1,2
	4,2	1200	2,0	41000	42000	71000	110000	154000	1,2
	5,2	1500	2,0	134000	131000	143000	164000	192000	1,2

	Adm. radial Displacement	Radial Stiffness	Adm. angular Displacement	Torsional stiffness					Relative Damping
				$C_{T \text{ dyn}}$ Nm/rad 2) 3)					
	$\Delta K_r$ mm 1) 2)	$C_r$ N/mm 2) 3)	$\Delta K_w$ 1) 2) 4)	$0,0 \times T_{KN}$	$0,25 \times T_{KN}$	$0,5 \times T_{KN}$	$0,75 \times T_{KN}$	$1,0 \times T_{KN}$	$\psi$
	0,70	150	2,0	290	320	440	580	740	1,1
	0,75	250	2,0	1160	1280	1410	1570	1810	1,1
	1,0	350	2,0	2230	2560	2810	3050	3300	1,1
	1,3	300	2,0	4000	5250	5950	6350	6650	1,1
	1,6	650	2,0	12000	14300	15450	16200	16600	1,1
	2,1	900	2,0	14000	17750	19700	20900	21750	1,1
	2,5	900	2,0	22000	31000	37300	41700	45200	1,1
	3,0	2500	2,0	60000	78000	88000	93500	96500	1,1
	3,5	1650	2,0	80000	93000	99000	102000	104000	1,1
	3,7	1800	2,0	90000	85500	99500	127000	165500	1,1
	4,2	3500	2,0	150000	135800	142300	161000	188500	1,1
	5,2	4000	2,0	360000	321500	333000	369000	421000	1,1

# FLEXIBLE COUPLINGS

## Stromag Periflex® Shaft Couplings

### Periflex® NC

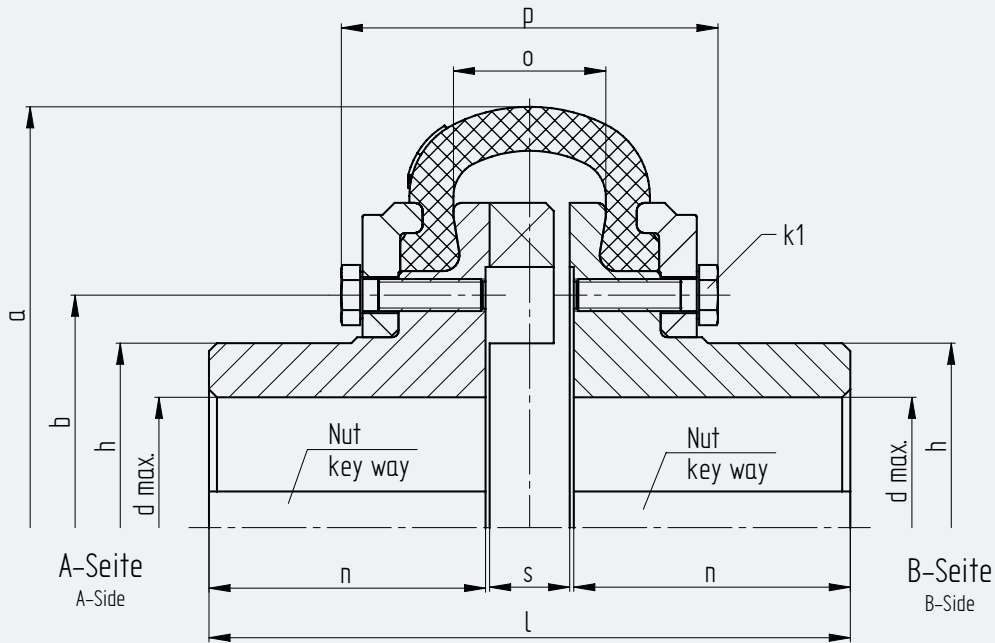

Coupling size	1 R	2 R	6 R	16 R	40 R	63 R	125 R	200 R	300 R	400 R	800 R	1500 R
Tire	201 R	203 R	206 R	210 R	214 R	218 R	222 R	225 R	426 R	828 R	1230 R	1832 R
Coupling size	1 X	2 X	6 X	16 X	40 X	63 X	125 X	200 X	300 X	400 X	800 X	1500 X
Tire	201 X	203 X	206 X	210 X	414 X	418 X	422 X	225 X	426 X	828 X	1230 X	1832 X
Torque $T_{KN}$ [Nm]	35	70	135	270	545	1000	2200	3400	5500	8200	13700	20500
Diameter [mm]												
a	86	104	136	178	210	263	310	370	402	450	550	700
b	43	54	70	91	116	152	188	240	270	260	290	360
$d_{max}$	24	30	42	55	65	85	110	110	120	130	150	180
h	34	43	58	76	92	120	154	155	170	185	210	260
Screws $k_1$	4x M5	4x M6	6x M6	6x M8	12x M8	6x M10	8x M10	8x M10	12x M12	12x M16	12x M16	12x M20
Tightening torque $M_A$ [Nm]	6	10	10	25	25	49	49	49	86	210	210	410
Length [mm]												
l	60	70	110	130	160	193	240	284	336	422	566	608
n	25	30	50	54,5	69	83,5	109	130	155	190	240	255
o	16	16	18	35	38	44	42	46	50	70	120	150
$p_{unclamped}$	60	65	76	107	110	133	150	163	165	210	306	395
s	8	8	8	19	20	24	20	22	24	40	84	96
Mass moment of inertia $J$ [kgm <sup>2</sup> ]												
JA side *)	0.00026	0.00054	0.00182	0.00686	0.0181	0.0632	0.1535	0.3990	0.5840	0.9240	2.2200	6.8040
JB side *)	0.00026	0.00054	0.00182	0.00686	0.0181	0.0632	0.1535	0.3990	0.5840	0.9240	2.2200	6.8040
Mass m [kg] *)	0.83	1.22	2.60	5.52	10.20	21.10	36.50	64.70	82.50	113.20	194.50	376.50

\*) at maximum bore diameter

# Stromag – Flexible Couplings

## Stromag Periflex® Shaft Couplings

### Periflex® NA

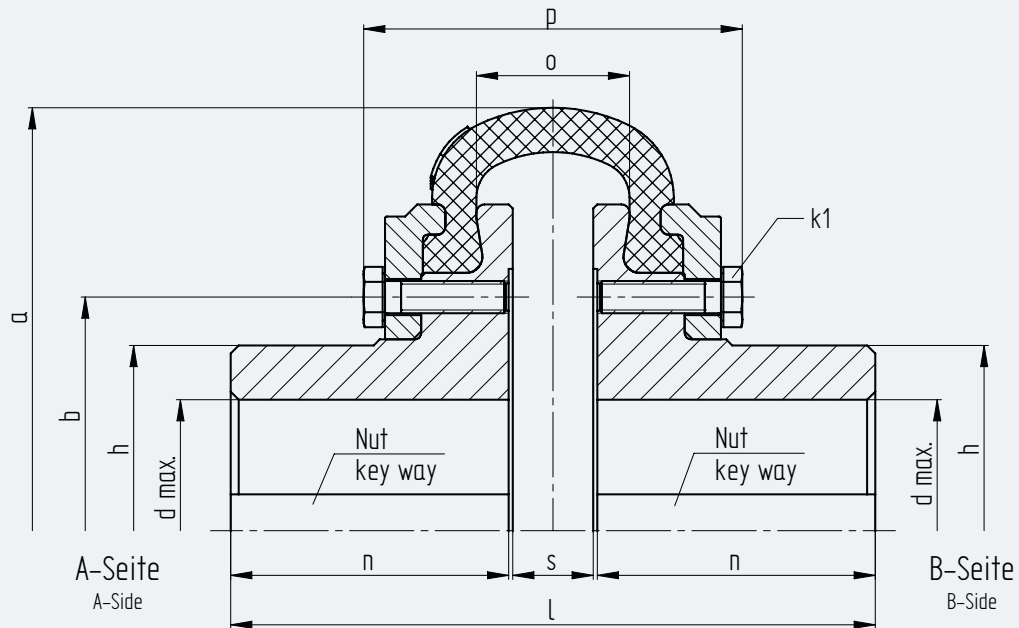

Coupling size	1 R	2 R	6 R	16 R	40 R	63 R	125 R	200 R	300 R	400 R	800 R	1500 R
Tire	201 R	203 R	206 R	210 R	214 R	218 R	222 R	225 R	426 R	828 R	1230 R	1832 R
Coupling size	1 X	2 X	6 X	16 X	40 X	63 X	125 X	200 X	300 X	400 X	800 X	1500 X
Tire	201 X	203 X	206 X	210 X	414 X	418 X	422 X	225 X	426 X	828 X	1230 X	1832 X
Torque $T_{KN}$ [Nm]	35	70	135	270	545	1000	2200	3400	5500	8200	13700	20500
Diameter [mm]												
a	86	104	136	178	210	263	310	370	402	450	550	700
b	43	54	70	91	116	152	188	240	270	260	290	360
d <sub>max</sub>	24	30	42	55	65	85	110	110	120	130	150	180
h	34	43	58	76	92	120	154	155	170	185	210	260
Screws $k_1$	4x M5	4x M6	6x M6	6x M8	12x M8	6x M10	8x M10	8x M10	12x M12	12x M16	12x M16	12x M20
Tightening torque $M_A$ [Nm]	6	10	10	25	25	49	49	49	86	210	210	410
Length [mm]												
l	60	70	110	130	160	193	240	284	336	422	566	608
n	25	30	50	54,5	69	83,5	109	130	155	190	240	255
o	16	16	18	35	38	44	42	46	50	70	120	150
p <sub>unclamped</sub>	60	65	76	107	110	133	150	163	165	210	306	395
s	8	8	8	19	20	24	20	22	24	40	84	96
Mass moment of inertia J [kgm <sup>2</sup> ]												
JA side *)	0.00024	0.00051	0.00175	0.00631	0.0168	0.0614	0.1487	0.3890	0.5680	0.8800	2.0318	6.3770
JB side *)	0.00024	0.00051	0.00175	0.00631	0.0168	0.0614	0.1487	0.3890	0.5680	0.8800	2.0318	6.3770
Mass m [kg] *)	0.79	1.18	2.50	5.20	9.72	20.00	35.70	64.10	81.70	110.50	183.80	361.00

\*) at maximum bore diameter

# FLEXIBLE COUPLINGS

## Stromag Periflex® Shaft Couplings

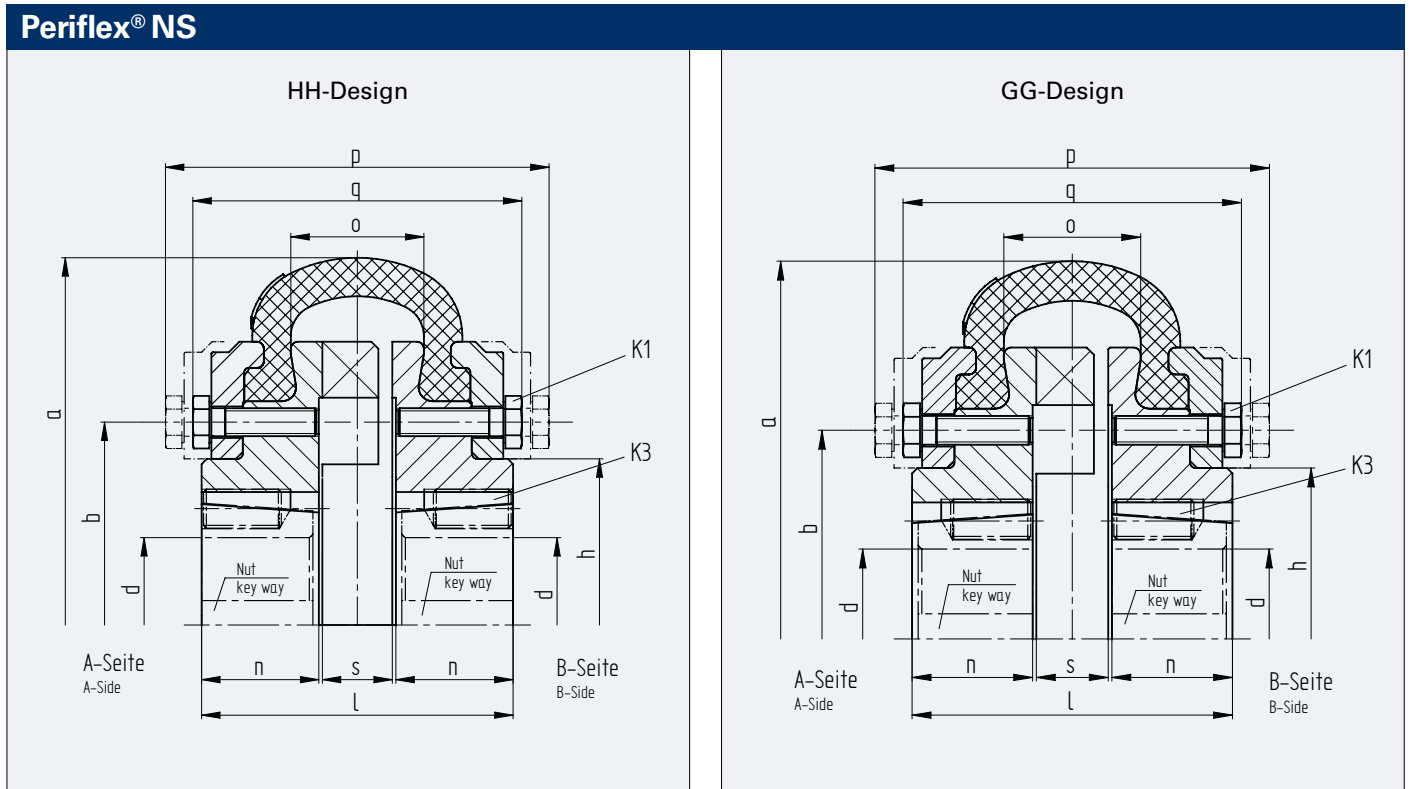

Coupling size	2 R		6 R		16 R		40 R		63 R		
Tire	203 R		206 R		210 R		214 R		218 R		
Coupling size	2 X		6 X		16 X		40 X		63 X		
Tire	203 X		206 X		210 X		414 X		418 X		
Design	HH	GG	HH	GG	HH	GG	HH	GG	HH	GG	
Taper bush	1008	1008	1108	1210	1615	1615	2012	2012	2525	3030	
Max. torque $T_{Smax}$ [Nm]	130	130	140	300	480	480	800	800	1300	2400	
Diameter [mm]											
a	104	104	136	136	178	178	210	210	263	263	
b	54	54	70	70	91	91	116	116	152	152	
$d_{max}$	24	24	25	30	40	40	50	50	60	75	
h	43	43	56	56	76	76	95	95	120	120	
Screws $K_1$	4x M6		6x M6		6x M8		12x M8		6x M10		
Screws $K_3$ (BSW)	2x 1/4"	2x 1/4"	2x 1/4"	2x 3/8"	2x 3/8"	2x 3/8"	2x 7/16"	2x 7/16"	2x 1/2"	2x 5/8"	
Length [mm]											
l	55	55	55	61	97	97	89	89	152	178	
n	22.5	22.5	22.5	25.5	38	38	33,5	33,5	63	76	
o	16	16	18	18	35	35	38	38	44	44	
$p_{unclamped}$	65	65	76	76	107	107	110	110	133	133	
q	55	55	60	60	90	90	94	94	113,5	113,5	
s	8	8	8	8	19	19	20	20	24	24	
Mass moment of inertia J [kgm <sup>2</sup> ]											
JA side *)	0.00051	0.00051	0.00161	0.00157	0.00658	0.00655	0.0165	0.0166	0.0613	0.0589	
JB side *)	0.00051	0.00051	0.00161	0.00157	0.00658	0.00655	0.0165	0.0166	0.0613	0.0589	
Mass m [kg] *)	1,08	1,08	2,1	1,91	5,02	5,01	8,25	8,25	19,89	17,43	



# FLEXIBLE COUPLINGS

## Stromag Periflex® Shaft Couplings

	125 R		200 R		300 R		400 R		800 R	
	222 R		225 R		426 R		828 R		1230 R	
	125 X		200 X		300 X		400 X		800 X	
	422 X		225 X		426 X		828 X		1230 X	
	HH	GG	HH	GG	HH	GG	HH	GG	HH	GG
	3535	3535	3535	3535	3535	4040	4040	4545	4545	5050
	4800	4800	5050	5050	5050	8700	8700	12400	12400	14200
	310	310	370	370	402	402	450	450	550	550
	188	188	240	240	270	270	260	260	290	290
	90	90	90	90	90	100	100	110	110	125
	154	154	155	155	170	170	185	185	210	210
	8x M10		8x M10		12x M12		12x M16		12x M16	
	3x 1/2"	3x 1/2"	3x 1/2"	3x 1/2"	3x 1/2"	3x 5/8"	3x 5/8"	3x 3/4"	3x 3/4"	3x 7/8"
	200	200	202	202	204	230	246	270	314	340
	89	89	89	89	89	102	102	114	114	127
	42	42	46	46	50	50	70	70	120	120
	150	150	163	163	165	165	210	210	306	306
	125,5	125,5	138,5	138,5	141	141	184	184	269	269
	20	20	22	22	24	24	40	40	84	84
	0.1425	0.1425	0.367	0.367	0.532	0.524	0.805	0.794	1.879	1.865
	0.1425	0.1425	0.367	0.367	0.532	0.524	0.805	0.794	1.879	1.865
	30,95	30,95	54,7	54,8	69,3	65,5	87,9	83,5	147,8	142,8

# FLEXIBLE COUPLINGS

## Stromag Periflex® Shaft Couplings

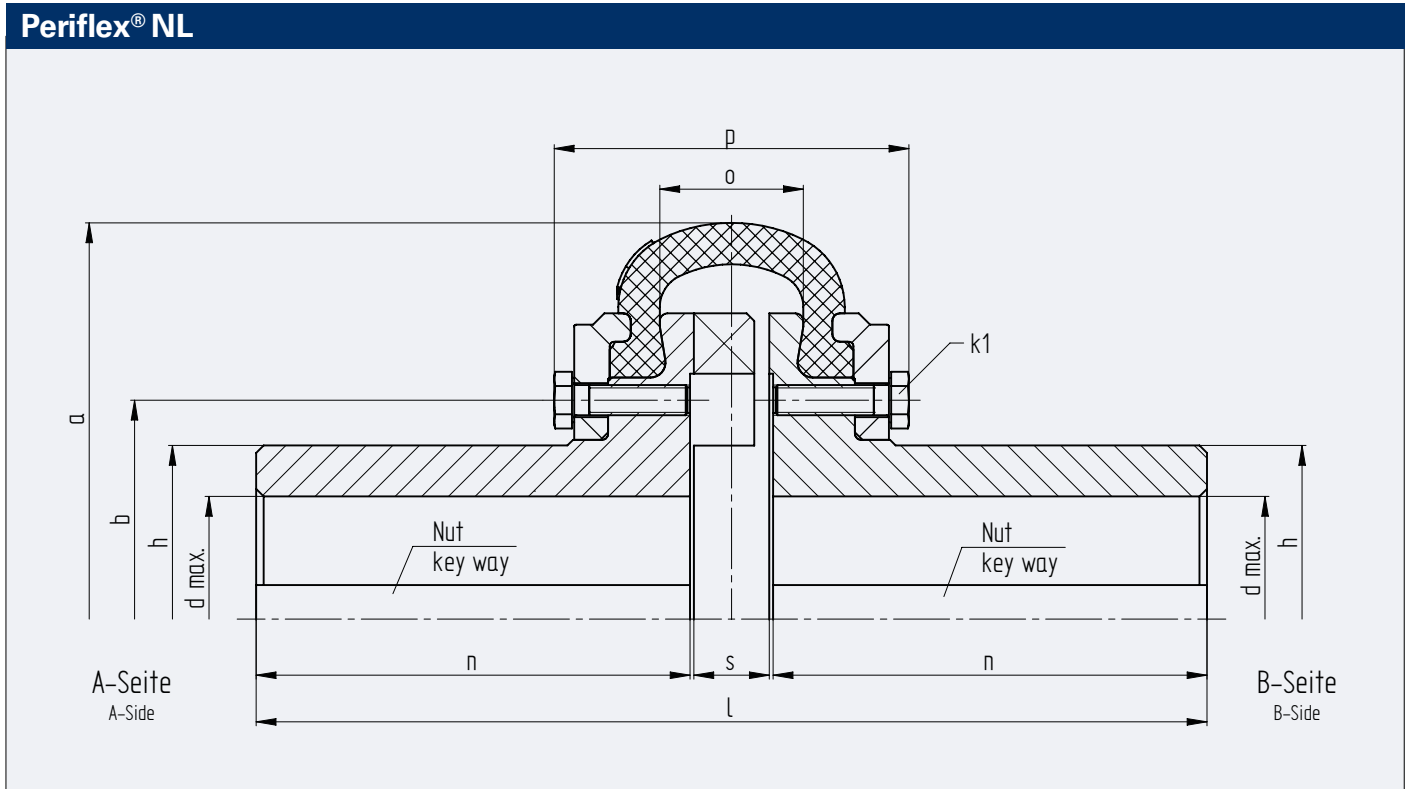

Coupling size	2 R	6 R	16 R	40 R	63 R	125 R
Tire	203 R	206 R	210 R	214 R	218R	222 R
Coupling size	2 X	6 X	16 X	40 X	63 X	125 X
Tire	203 X	206 X	210 X	414 X	418 X	422 X
Torque $T_{KN}$ [Nm]	70	135	270	545	1000	2200
Diameter [mm]						
a	104	136	178	210	263	310
b	54	70	91	116	152	188
$d_{max}$	30	42	55	65	85	110
h	42	58	76	92	120	154
Screws $k_1$	4xM6	6xM6	6xM8	12xM8	6xM10	8xM10
Tightening torque $M_A$ [Nm]	10	10	25	25	49	49
Length [mm]						
l	88	138	191	252	260	330
n	39	64	85	115	117	154
o	16	18	35	38	44	42
$p_{unclamped}$	65	76	107	110	133	150
s	8	8	19	20	24	20
Mass moment of inertia $J$ [kgm <sup>2</sup> ]						
JA side *)	0.00055	0.00191	0.00742	0.0199	0.0671	0.1677
JB side *)	0.00055	0.00191	0.00742	0.0199	0.0671	0.1677
Mass $m$ [kg] *)	1.3	2.9	6.5	12.5	24.0	42.8

\*) at maximum bore diameter

# FLEXIBLE COUPLINGS

## Stromag Periflex® Shaft Couplings

### Periflex® NP

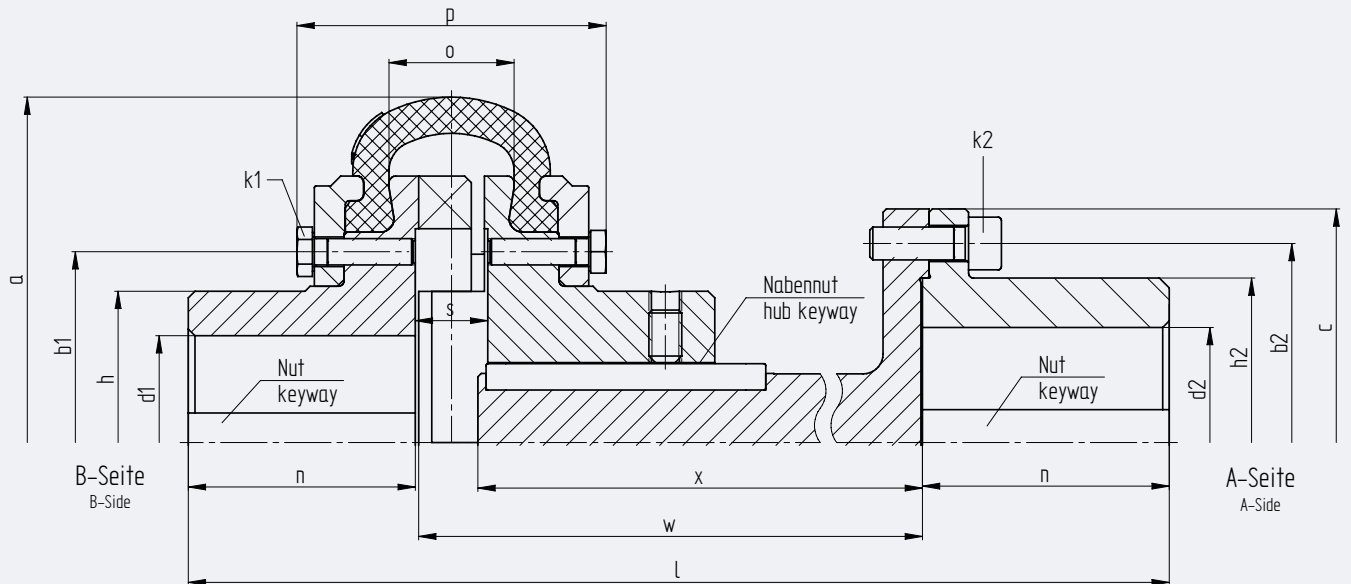

Coupling size	2 R		6 R		16 R		40 R			63 R		125 R		
Tire	203 R		206 R		210 R		214 R			218 R		222 R		
Coupling size	2 X		6 X		16 X		40 X			63 X		125 X		
Tire	203 X		206 X		210 X		414 X			418 X		422 X		
Design	100	140	100	140	100	140	100	140	180	140	180	180	250	350
Extension S <sub>PN</sub>	011	012	021	022	031	032	041	042	043	051	052	062	063	073
<b>Diameter [mm]</b>														
a	104		136		178		210			263		310		310
b1	54		70		91		116			152		188		
b2	63,5		81		100		121			137		184		212
c	79		97		120		142			160		218		245
d1 <sub>max</sub>	30		42		55		65			85		110		110
d2 <sub>max</sub>	34		45		55		70			80		100		110
h1	43		58		76		92			120		154		154
h2	48		65		80		100			112		140		168
Screws k1	4xM6		6xM6		6xM8		12xM8			6xM10		8xM10		8xM10
Screws k2	8xM6		8xM8		8xM10		8xM10			8xM12		10xM16		10xM20
<b>Length [mm]</b>														
l	181	221	211	251	221,5	261,5	245	285	325	309,5	349,5	395	465	585
n1	30	30	50	50	54,5	54,5	69	69	69	83,5	83,5	109	109	109
n2	50	50	60	60	66	66	75	75	75	85	85	105	105	125
o	16	16	18	18	35	35	38	38	38	44	44	42	42	42
p <sub>unclamped</sub>	65	65	76	76	107	107	110	110	110	133	133	150	150	150
s	8	8	8	8	19	19	20	20	20	24	24	20	20	20
w	100	140	100	140	100	140	100	140	180	140	180	180	250	350
x	94	134	92	134	94	134	82	122	162	122	162	163	233	333
<b>Mass moment of inertia J [kgm<sup>2</sup>]</b>														
JA side *)	0.0011	0.0011	0.0038	0.0038	0.0123	0.0123	0.0306	0.0310	0.0311	0.0891	0.0892	0.2599	0.2574	0.3475
JB side *)	0.0005	0.0005	0.0018	0.0018	0.0069	0.0069	0.0181	0.0180	0.0180	0.0632	0.0632	0.1535	0.1535	0.1535
Mass m [kg] *)	2.40	2.50	4.95	5.10	9.67	9.91	16.6	17.2	17.7	32.3	32.8	61.7	62.7	76.8
*) at maximum bore diameter														

# FLEXIBLE COUPLINGS

## Stromag Periflex® Shaft Couplings

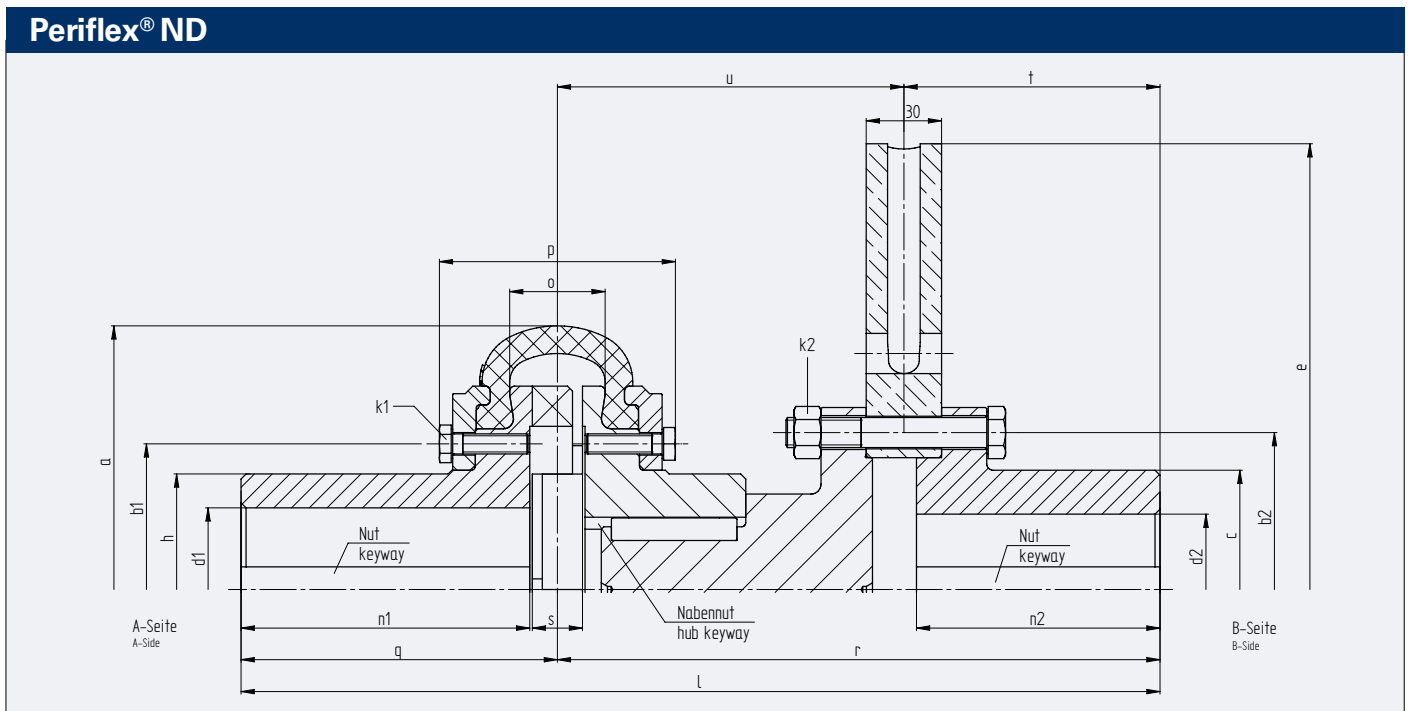

Coupling size	40 R		63 R			125 R				
Tire	214 R		218 R			222 R				
Coupling size	40 X		63 X			125 X				
Tire	414 X		418 X			422 X				
Brake disc Ø [mm]	315	355	315	355	400	355	400	450	500	550
Speed n [rpm]	3000	2500	2700	2500	2400	2500	2400	2100	1900	1800
Diameter [mm]										
a	210	210	263	263	263	310	310	310	310	310
b1	116	116	152	152	152	188	188	188	188	188
b2	105	125	105	125	140	125	140	146	190	190
d1 <sub>max</sub>	65	65	85	85	85	110	110	110	110	110
d2 <sub>max</sub>	55	65	55	60	70	60	75	75	100	100
e	315	355	315	355	395	355	395	445	495	550
h1	92	92	120	120	120	154	154	154	154	154
h2	80	95	80	95	105	95	105	110	150	150
Screws k1	12xM8	12xM8	6xM10	6xM10	6xM10	8xM10	8xM10	8xM10	8xM10	8xM10
Screws k2	9xM10	9xM12	9xM10	9xM12	9xM14	9xM12	9xM14	12xM16	12xM18	12xM18
Length [mm]										
l	366		393			445		478		465
n1	115		117			154		154		154
n2	97		97			97		130		130
o	38		44			44		42		42
p <sub>unclamped</sub>	110		133			133		150		150
q	126		130			130		165		165
r	240		263			253		280		300
s	20		24			24		20		20
t	102		102			102		135		135
u	138		161			151		178		165
Mass moment of inertia J [kgm <sup>2</sup> ]										
JA side *)	0.0199	0.0199	0.0672	0.0672	0.0672	0.1677	0.1677	0.1677	0.1677	0.1677
JB side *)	0.1691	0.2599	0.2294	0.3073	0.4420	0.4001	0.5361	0.7609	1.113	1.534
Mass m [kg] *)	29.7	34.9	42.6	48.1	54.1	67.9	74.4	81.7	94.0	100.7

\*) at maximum bore diameter

# FLEXIBLE COUPLINGS

## Stromag Periflex® Shaft Couplings

200 R					300 R			400 R			800 R	
225 R					426 R			828 R			1230 R	
200 X					300 X			400 X			800 X	
225 X					426 X			828 X			1230 X	
400	450	500	550	630	500	550	630	630	710	800	710	800
2000	2000	1900	1800	1500	1900	1800	1500	1500	1300	1200	1250	1200
370	370	370	370	370	402	402	402	450	450	450	550	550
240	240	240	240	240	270	270	270	260	260	260	290	290
140	146	190	190	205	190	190	205	205	230	260	230	260
110	110	110	110	110	120	120	120	130	130	130	150	150
75	75	100	100	100	100	100	100	100	120	130	120	130
395	445	495	550	625	495	550	625	625	705	795	705	795
155	155	155	155	155	170	170	170	185	185	185	210	210
105	110	150	150	150	150	150	150	150	180	200	180	200
8xM10	8xM10	8xM10	8xM10	8xM10	12xM12	12xM12	12xM12	12xM16	12xM16	12xM16	12xM16	12xM16
9xM14	12xM16	12xM18	12xM18	12xM20	12xM18	12xM18	12xM20	12xM20	12xM22	12xM24	12xM22	12xM24
436.5	469.5		484.5	608	516	646	566	738				
130	130		130	155	155	190	190	240				
97	130		130	130	130	130	130	130				
46	46		46	50	50	70	70	120				
163	163		163	165	165	210	210	306				
142	142		142	168	168	211	211	283				
294.5	327.5		342.5	440	348	435	355	455				
22	22		22	24	24	40	40	84				
102	135		135	135	135	135	135	135				
192.5	192.5		207.5	305	213	300	220	320				
0.3990	0.3990	0.3990	0.3990	0.3990	0.5840	0.5840	0.5840	0.9240	0.9240	0.9240	2.220	2.220
0.7787	1.0051	1.366	1.788	2.812	1.587	1.702	2.991	3.266	4.668	7.371	5.995	8.692
99.6	107.1	122.2	129.0	148.7	154.7	148.7	166.4	208.5	215.3	250.7	312.2	346.2

# FLEXIBLE COUPLINGS

## Stromag Periflex® Shaft Couplings

### Periflex® NB

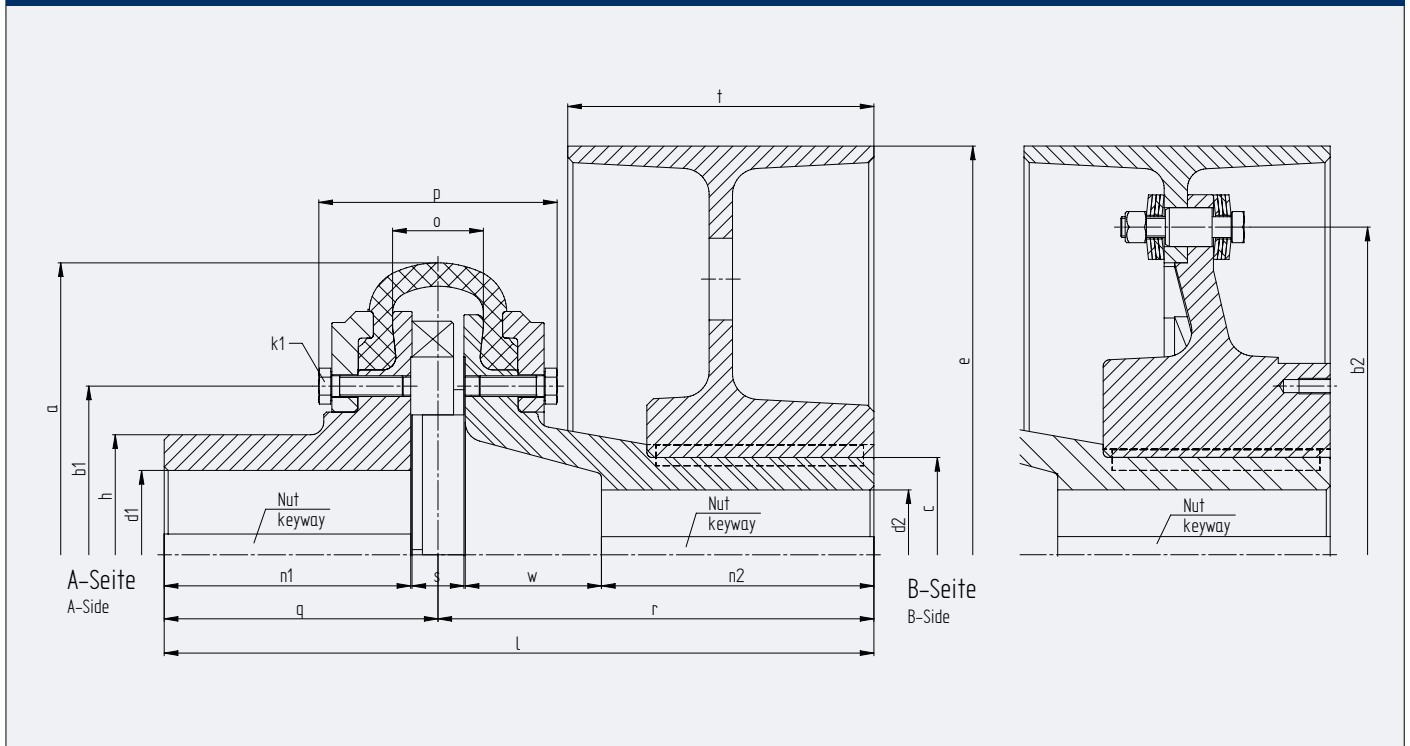

Coupling size	40 R	63 R	125 R	200 R	300 R	400 R	800 R				
Tire	214 R	218 R	222 R	225 R	426 R	828 R	1230 R				
Coupling size	40 X	63 X	125 X	200 X	300 X	400 X	800 X				
Tire	414 X	418 X	422 X	225 X	426 X	828 X	1230 X				
Brake disc Ø [mm]	200	200	250	315	315	400	400	500	630	630	710
Speed n [rpm]	3000	2500	2500	2500	2000	2000	2000	2000	1600	1250	1250
Diameter [mm]											
a	210	263	263	310	370	370	402	402	450	550	550
b1	116	152	152	188	240	240	270	270	260	290	290
b2	-	-	-	-	-	-	-	-	505	505	505
c	85	85	100	125	140	140	140	140	150	170	170
d1 <sub>max</sub>	65	85	85	110	110	110	120	120	130	150	150
d2 <sub>max</sub>	55	55	60	80	90	90	90	90	100	120	120
e	200	200	250	315	315	400	400	500	630	630	710
f	70	75	75	98	105	105	110	110	125	140	140
h	92	120	120	154	155	155	170	170	185	210	210
Screws k1	12xM8	6xM10	8xM10	8xM10	12xM12	12xM16	12xM16	12xM16	12xM16	12xM16	12xM16
Length [mm]											
l	252	267	287	363	347.5	379.5	403	433	547	659	688
n1	115	117	117	154	130	130	155	155	190	240	240
n2	90	80	100	120	120	130	130	160	210	210	235
o	38	44	44	42	46	46	50	50	70	120	120
p <sub>unclamped</sub>	110	133	133	150	163	163	165	165	210	306	306
q	126	130	130	165	142	142	168	168	211	283	283
r	126	137	157	198	205.5	237.5	235	265	336	376	405
s	20	24	24	20	22	22	24	24	40	84	84
t	75	75	95	118	118	150	150	190	236	236	265
w	26	45	45	68	74.5	96.5	93	93	106	124	128
Mass moment of inertia J [kgm <sup>2</sup> ]											
JA side *)	0.0200	0.0671	0.0671	0.1677	0.3990	0.3990	0.5840	0.5840	0.9260	2.220	2.220
JB side *)	0.0596	0.1040	0.2067	0.5620	0.7890	1.510	1.683	3.316	9.006	10.091	16.44
Mass m [kg*]	18.9	30.1	39.9	71.6	91.9	115.2	131.2	159.1	279.3	348.9	394.7
*) at maximum bore diameter											

### Characteristics of Periflex® Shaft Couplings

<b><math>T_{KN}</math></b>	
<p>The nominal torque of the coupling can be permanently transferred over the entire admissible speed range. It must not exceed the nominal torque <math>T_N</math> of the system.</p>	$T_{KN} \geq T_N$
<b><math>T_{Kmax}</math></b>	
<p>The maximum torque <math>T_{Kmax}</math> of the coupling can be endured as a peak load and must not be exceeded by peak torques <math>T_{max}</math> when the system is operating in normal, transient conditions. Normal transient operating conditions of a system are unavoidable and occur repeatedly (such as start and stop procedures, resonance passes, switchovers, accelerations, etc.).</p> <p>The maximum torque of the coupling can be tolerated for a short period of time, i. e. without thermal influences on the coupling, as a swelling or alternating load.</p> <p>Overloading the Stromag Periflex® Shaft Coupling with the system's irregular, non-stationary peak torques shortens the service life.</p> <p>Irregular, transient peak torques of a system can be avoided and are not part of the planned operating pattern (for example, emergency stop, synchronisation failure, short circuit, etc.).</p>	$T_{Kmax} \geq T_{max}$
<b><math>T_{Kw}</math></b>	
<p>The admissible continuous alternating torque indicates the amplitude of the continuously permissible periodic torque fluctuation. This torque may be superimposed on a base load equal to <math>T_{KN}</math>.</p>	
<b><math>\Delta K_a</math></b>	
<p>Admissible axial displacement of the coupling. The axial displacement <math>\Delta W_a</math> of the shafts must be smaller than <math>\Delta K_a</math>.</p>	$\Delta K_a \geq \Delta W_a$
<b><math>\Delta K_r</math></b>	
<p>Admissible radial displacement of the coupling. The radial displacement <math>\Delta W_r</math> of the shafts must be smaller than <math>\Delta K_r</math>.</p> <p>The specified values for <math>\Delta K_r</math> are related to the maximum speed of the coupling. The admissible radial displacement must be reduced at ambient temperatures <math>T_U</math> above 30°C by the temperature factor <math>S_{9Kr}</math>; see diagram on page 25.</p>	$\Delta K_r \geq \Delta W_r$ $\Delta K_r(T_U) = \frac{\Delta K_r}{S_{9Kr}}$
<b><math>\Delta K_w</math></b>	
<p>Admissible angular displacement of the coupling. The angular displacement of the shafts <math>\Delta W_w</math> must be smaller than <math>\Delta K_w</math>.</p> <p>The specified value for <math>\Delta K_w</math> refers to the maximum speed of the coupling.</p> <p>However, this value may only be fully used if there are no further radial displacements. The admissible angular displacement must be reduced at ambient temperatures above 30°C by the temperature factor <math>S_{9Kw}</math>; see diagram on page 25.</p>	$\Delta K_w \geq \Delta W_w$ $\Delta K_w(T_U) = \frac{\Delta K_w}{S_{9Kw}}$

# FLEXIBLE COUPLINGS

## Stromag Periflex® Shaft Couplings

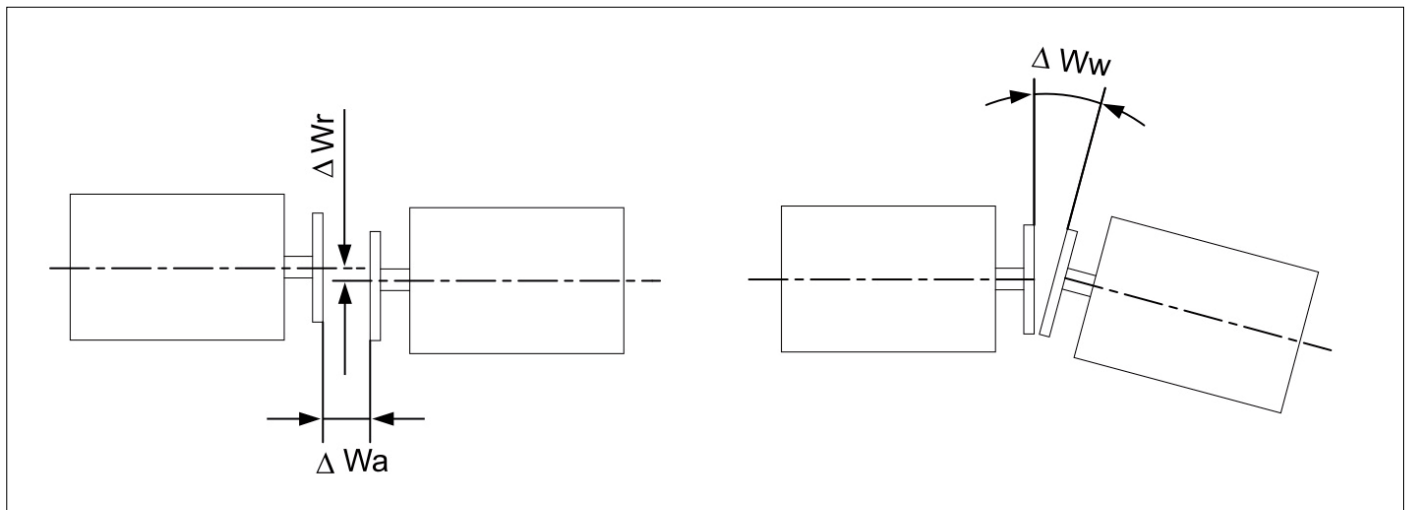

<b>C<sub>a</sub></b>	
<p>The axial stiffness indicates the axial restoring force after axial displacement. At ambient temperatures above 30°C, the specified values must be reduced by temperature factor S<sub>9C</sub>; see diagram on page 25.</p>	$C_a(T_U) = \frac{C_a}{S_{9C}}$

<b>C<sub>r</sub></b>	
<p>The radial stiffness indicates the radial restoring force after radial displacement. At ambient temperatures above 30°C, the specified values must be reduced by the temperature factor S<sub>9C</sub>; see diagram on page 25.</p>	$C_r(T_U) = \frac{C_r}{S_{9C}}$

<b>C<sub>Tdyn</sub></b>	
<p>The dynamic torsional stiffness indicates the relationship of a torque amplitude to the rotational angle amplitude during an oscillation process.</p> <p>With Periflex® Shaft Coupling, the C<sub>Tdyn</sub> value is not constant (progressive characteristic) over the coupling torque and also changes with the amplitude, frequency and temperature of the tyre.</p> <p>The specifications for C<sub>Tdyn</sub> are based on an alternating torque of 0.25 x T<sub>KN'</sub> a frequency of 10 Hz and an ambient temperature T<sub>U</sub> below 30°C.</p> <p>For higher ambient temperatures, the indicated values must be reduced by the temperature factor S<sub>9C</sub>; see diagram on page 25.</p>	$C_{Tdyn} = \frac{T_{el}}{\varphi_w}$ $C_{Tdyn}(T_U) = \frac{C_{Tdyn}}{S_{9C}}$

<b>Ψ</b>	
<p>The relative damping is a measure of the coupling's ability to convert part of the oscillation energy into heat.</p> <p>The relative damping can be determined with the damping loop (hysteresis loop). The area A<sub>D</sub> is a measure of the damping work W<sub>D</sub> during an oscillation cycle. The area A<sub>el</sub> represents flexible deformation work W<sub>el</sub> at a given load.</p> <p>The specifications for Ψ are based on a coupling torque of 0.75 x T<sub>KN'</sub>, an alternating torque of 0.25 x T<sub>KN</sub> and a frequency of 10 Hz with a coupling in warm operating conditions and a surface temperature of approximately 30°C.</p>	$\Psi = \frac{W_D}{W_{el}} = \frac{A_D}{A_{el}}$



# FLEXIBLE COUPLINGS

## Stromag Periflex® Shaft Couplings

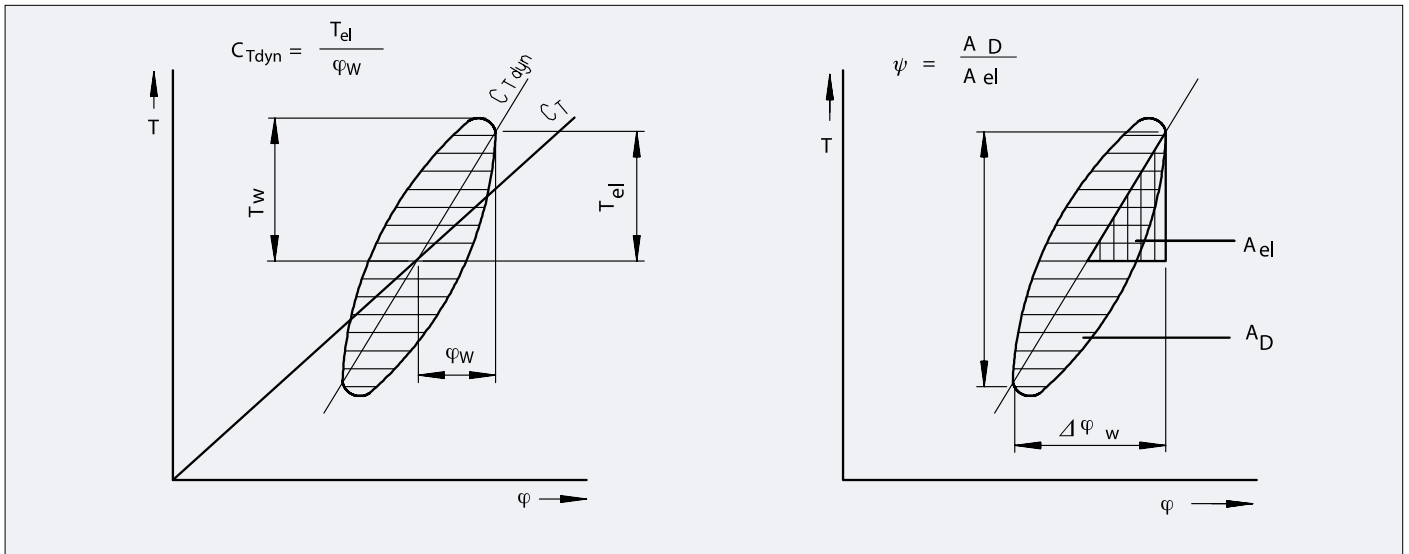

### $S_{\theta Kr}$ , $S_{\theta Kw}$ and $S_{\theta C}$

Temperature factors should take into account the decrease in the physical properties of flexible rubber materials due to excessive heating.

The coupling temperature is determined by the ambient temperature as well as internal heating caused by internal material friction in the rubber volume as a result of alternating torques and alternating loads due to shaft displacement.

At higher ambient temperatures, the coupling characteristics  $\Delta K_r$  and  $\Delta K_w$  must be reduced by the temperature factors  $S_{\theta Kr}$  and  $S_{\theta Kw}$ ,  $C_{Tdyn}$ ,  $C_r$  and  $C_a$  are set to a value that is reduced by the temperature factor  $S_{\theta C}$  due to heating.

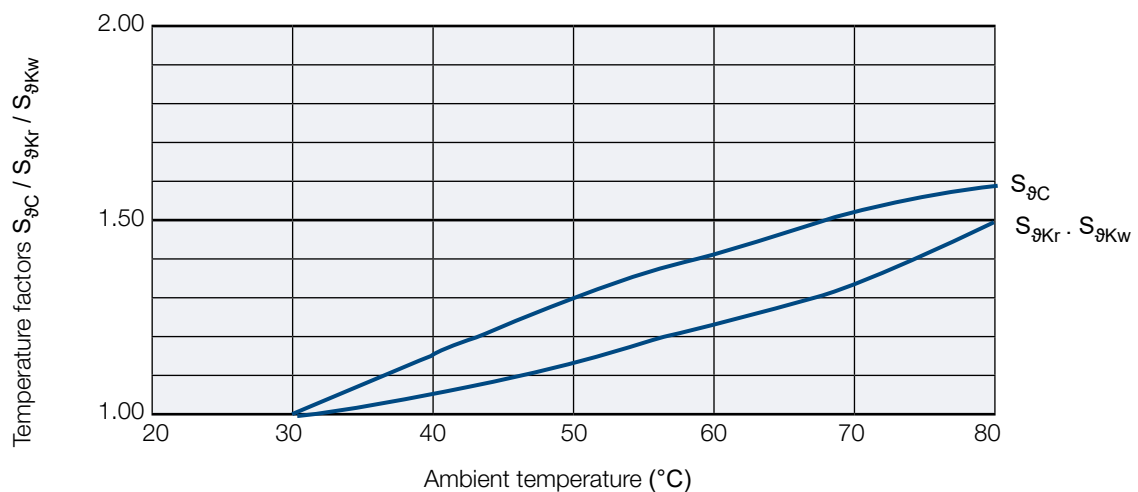

# FLEXIBLE COUPLINGS

## Stromag Periflex® Shaft Couplings

### Coupling design, question sheet

Main engine		
Engine type (electric, internal combustion engine, etc.)		
Motor type (make, type)		
Motor installation (rigid, flexible)		
Engine housing (SAE)		
Flywheel centring diameter		mm
Power rating		kW
Nominal speed		rpm
Speed range		rpm
Nominal torque		Nm
Maximal torque (tilting moment)		Nm
Moment of inertia		kgm <sup>2</sup>
Number of hourly starts or reversals		
Gear		
Gear ratio		
Moment of inertia		kgm <sup>2</sup>
Driven side		
Type (generator, fan, compressor, fixed or variable pitch propeller)		
Main or auxiliary drive		
Type of construction (free-standing or flange-mounted)		
Moment of inertia		kgm <sup>2</sup>
Coupling		
Application site in the drive train (please enclose schematic sketch)		
Bore dimensions for coupling hub A-side and B-side		mm
Ambient temperature		°C, °K
Classification society		

# FLEXIBLE COUPLINGS

## Stromag Periflex® Shaft Couplings

### Use in potentially explosive environments, question sheet

Field of application		<input type="radio"/>	Group II (above ground application)
Potentially explosive atmosphere of air with		<input type="radio"/>	Gas
		<input type="radio"/>	Dust
Use in zone (category)	Gas	<input type="radio"/>	Zone 1 (category 2G)
		<input type="radio"/>	Zone 2 (category 3G)
	Dust	<input type="radio"/>	Zone 21 (category 2D)
		<input type="radio"/>	Zone 22, conductive (category 2D)
		<input type="radio"/>	Zone 22, insulating (category 3D)
Temperature class for gas atmosphere	Gas	<input type="radio"/>	T1
		<input type="radio"/>	T2
		<input type="radio"/>	T3
		<input type="radio"/>	T4
Maximum admissible surface temperature	Dust	<input type="radio"/>	120°C
		<input type="radio"/>	< 120°C
		<input type="radio"/>	-20°C to +40°C
Ambient temperature		<input type="radio"/>	Deviating ambient temperatures only with restrictions



# Stromag™

[stromag.com](http://stromag.com)

## Germany

Hansstraße 120

59425 Unna - Germany

+49 2303 102 - 0

[regalrexnord.com](http://regalrexnord.com)

The proper selection and application of products and components, including assuring that the product is safe for its intended use, are the responsibility of the customer. To view our Application Considerations, please visit <https://www.regalrexnord.com/Application-Considerations>.

To view our Standard Terms and Conditions of Sale, please visit <https://www.regalrexnord.com/Terms-and-Conditions-of-Sale> (which may redirect to other website locations based on product family).

"Regal Rexnord" is not indicative of legal entity. Refer to product purchase documentation for the applicable legal entity. Regal Rexnord and Stromag are trademarks of Regal Rexnord Corporation or one of its affiliated companies.

© 2025 Regal Rexnord Corporation, All Rights Reserved. MCC-P-8467-SG-EN-A4 03/25



 **RegalRexnord™**